

Man Baskets



Safe. Efficient. Strong.

“The best money we’ve ever spent on crane accessories”

Mike Dawson VP Specialty Crane & Rigging

RUGGED CONSTRUCTION and compliance with engineering standards are the benchmarks of all Boscaro equipment. Utilizing 30+ years of industry knowledge, Boscaro is one of the world’s leading manufacturers of industrial equipment.

SPECIFICATIONS

- EZ™ Test Weight System for quick test weight set-up and removal.
- Built to meet and/or exceed all OSHA & ASME requirements.
- Tested to 9x the legal requirement
- Multiple patents pending

BOSCARO MAN BASKETS

KEY FEATURES

- A** 4 upper & 4 lower rigging points
- B** Removable roof gives you 2 manbaskets in 1
- C** Fully functional access door
- D** Rollers allows safe transfer up & down side walls
- E** 43.5" high guard railing
- F** Wrap around inner safety railing
- G** Top grade steel construction
- H** 24" lower enclosure minimizes tools from falling
- I** 24" built in tool crib
- J** The EZ™ Test Weight System
- K** Roof has 2 lanyard connection points
- L** Powder coated finish

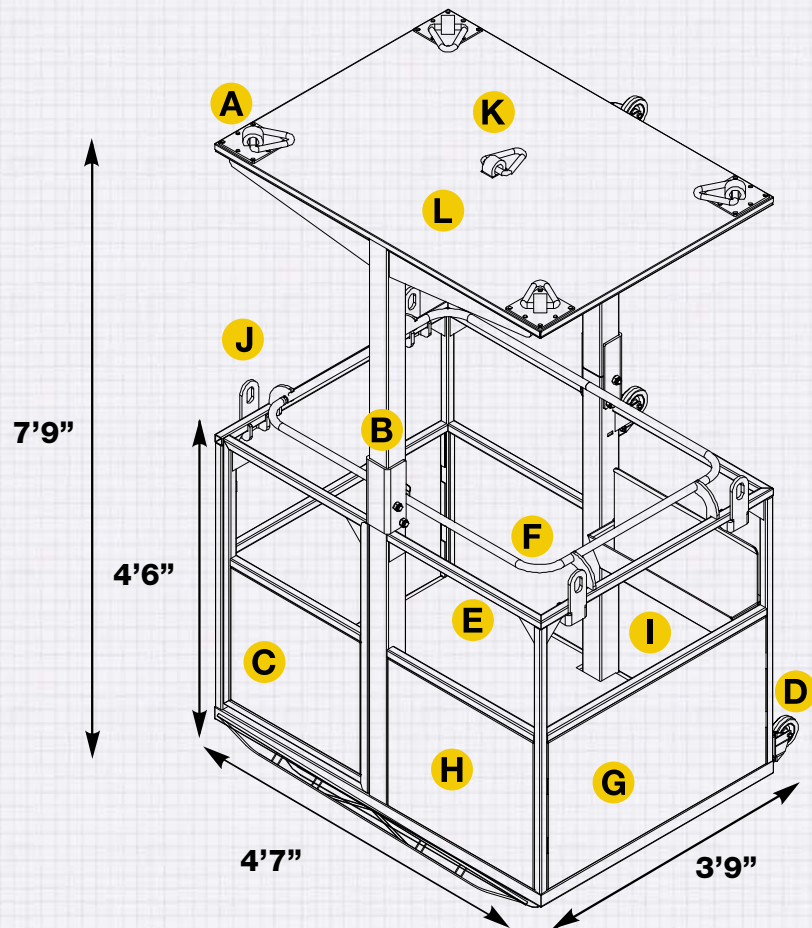

- Meets and **exceeds** all OSHA & ASME standards
- Tested to **9 times** the legal requirements
- Bottom section: **463 lb**
- Top section: **200 lb**
- Test weights: **815 lb**

Boscaro Equipment?

✓ Designed for safety

✓ Solid construction

✓ Highly competitive

Boscaro equipment is distributed exclusively through the Eagle West Equipment dealer network.

Call 1-877-852-2192 for immediate support.

WWW.EAGLEWESTEQUIPMENT.COM